

# SPECIFICATIONS

## BANC AVEC DOSSIER BENCH WITH BACKREST

- 100% PLASTIC RECYCLÉ (COULEUR : SABLE)  
100% RECYCLED PLASTIC (COLOR : SAND)
- QUINCAILLERIE EN ACIER INOXYDABLE  
STAINLESS STEEL HARDWARE
- GARANTIE DE 10 ANS  
10-YEAR WARRANTY
- POIDS APPROXIMATIF : 145 LBS  
APPROXIMATE WEIGHT : 145 LBS

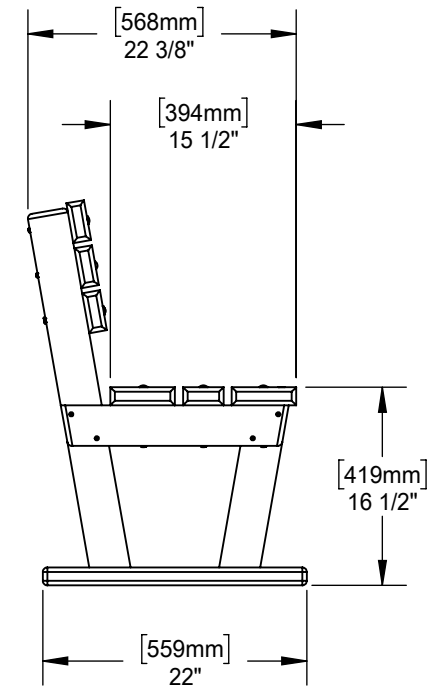
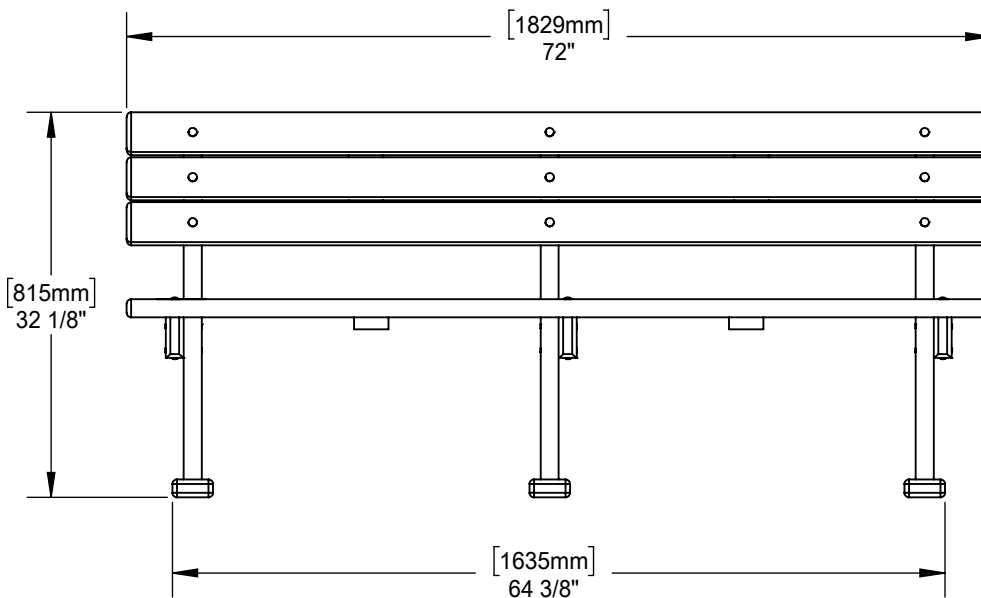
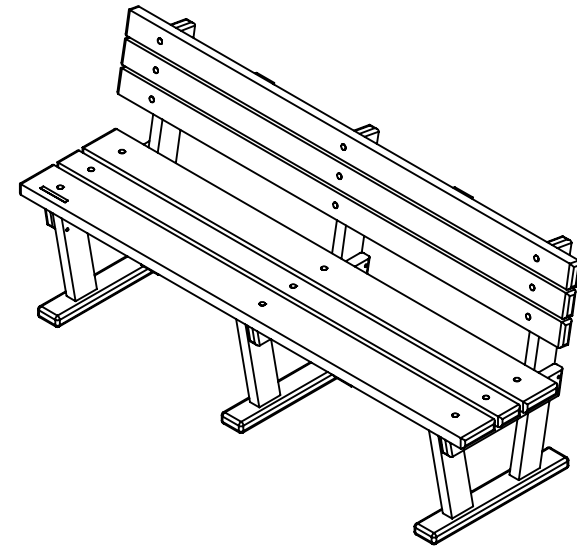

# DE PIECE / PRODUCT #  
68.1606

BANC AVEC DOSSIER  
PLASTIC BENCH WITH BACKREST

PROJECTION

FORMAT  
A

UNITES / UNITS  
PO (IN) / MM

DATE  
2016-03-22

**NORDESCO**<sub>inc.</sub>  
WWW.NORDESCO.COM