

ITEM NO.	PART NUMBER	DESCRIPTION	QTY.
1	BL-TIMERSTABLE-STRINGER	TIMER'S TABLE STRINGER	4
2	BL-20774	ALUMINUM RETAINER CLIP 1-5/16" LENGTHS	24
3	HW-B-5000	GR 2 CARRIAGE BOLT MECH. GALV. 5/16" x 1-1/4"	24
4	BL-SLEEPER-96	2" x 6" x 96" HDPE RECYCLED SLEEPER	4
5	HW-N-10000	3/8" SERRATED FLANGE NUT MECH. GALV.	19
6	HW-N-10001	5/16" SERRATED FLANGE NUT MECH. GALV.	24
7	HW-B-50003	GR 5 CARRIAGE BOLT MECH. GALV. 3/8 x 2-1/2	8
8	HW-B-40000	GR 5 HEX MECH. GALV. 3/8" x 1-1/4"	11
9	BL-60-22	60-22 DIAGONAL BRACE	6
10	BL-17400A	END CAP 9-1/2"	6
11	AL-16723A-18	2" x 10" NOMONAL BLEACHER PLANK ANODIZED FINISH 18'	3
12	HW-R-10000	ALUMINUM POP RIVET 3/16" x 0.251-0.375	12

NOTES:

ITEM 4 SLEEPERS INSTALLED FOR A PORTABLE TIMER'S TABLE

THE FOLLOWING COMPONETS ARE OPTIONAL

(ITEM 4 QTY.4), (ITEMS 7 QTY.8) AND (ITEM 5 QTY.8)

NOTES:

IF BOLTING TO CONCRETE HARDWARE SUPPLIED BY OTHERS. RECOMMENDED HARDWARE 3/8" x 3" WEDGE BOLT

THIS DRAWING AND ALL INFORMATION CONTAINED HEREIN IS THE PROPERTY OF SPORT SYSTEMS CANADA INC. AND IS NOT TO BE REPRODUCED WITHOUT THE WRITTEN PERMISSION OF THIS MANUFACTURER. WE ASSUME NO RESPONSIBILITY FOR UNAUTHORIZED USE OF THIS DRAWING. SPORT SYSTEMS CANADA INC. IS NOT RESPONSIBLE FOR LOCAL PERMITS AND OCCUPANCY REQUIREMENTS.



Building a Better Game

28 Industrial Drive, Box 940
Almonte, Ontario, Canada
K0A 1A0

www.ssci.ca
1.877.600.4667
T 613.256.1112
F 613.256.5876

CLIENT

S.S.C.I.

TITLE

TIMER'S TABLE 18' LONG

REV.	DATE	DWG No:
	Feb. 03/2014	BL-TIMERSTABLE-18

SCALE	DES.	PAGE
N.T.S.	John Cox	1 of 5

NOTES:
SEE SHEET 1 FOR BALLOON ITEM QUANTITIES

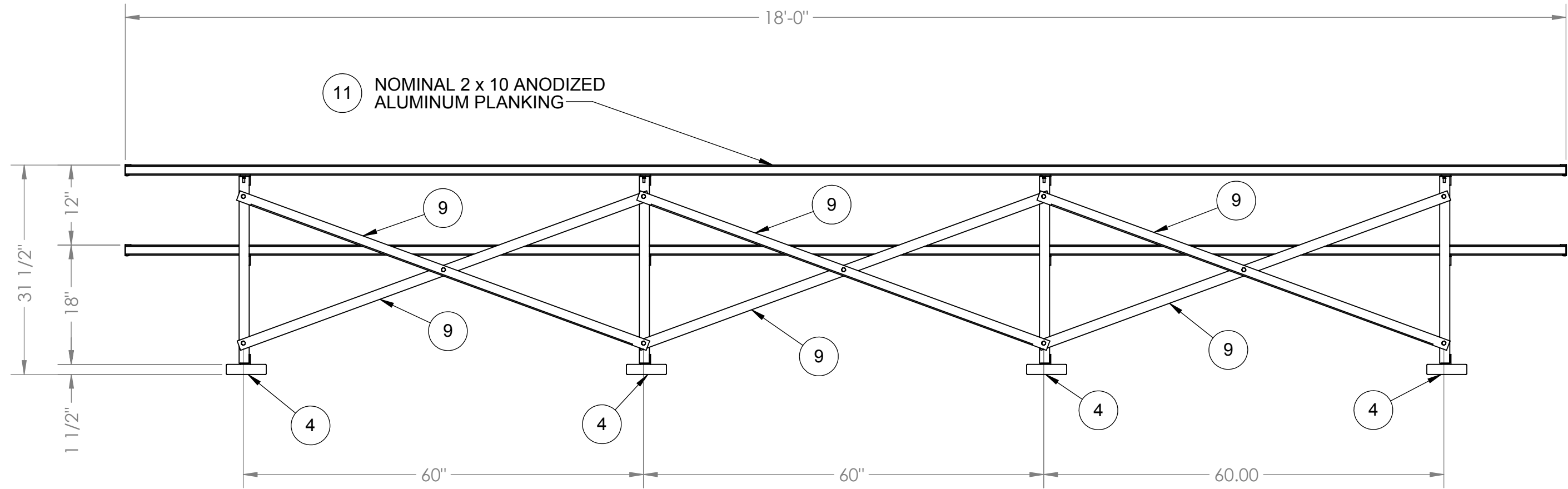

REAR ELEVATION

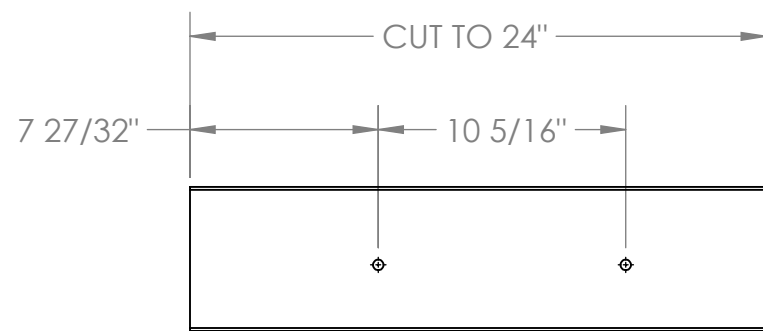

ITEM 4 SLEEPER

PROPRIETARY AND CONFIDENTIAL
THE INFORMATION CONTAINED IN THIS DRAWING IS THE SOLE PROPERTY OF <INSERT COMPANY NAME HERE>. ANY REPRODUCTION IN PART OR AS A WHOLE WITHOUT THE WRITTEN PERMISSION OF <INSERT COMPANY NAME HERE> IS PROHIBITED.

		UNLESS OTHERWISE SPECIFIED:		NAME	DATE	S.S.C.I.			
		DIMENSIONS ARE IN INCHES TOLERANCES: FRACTIONAL ± ANGULAR: MACH ± BEND ± TWO PLACE DECIMAL ± THREE PLACE DECIMAL ±		DRAWN	John Cox			03/02/2014	
		INTERPRET GEOMETRIC TOLERANCING PER:		CHECKED			TITLE: TIMER'S TABLE 18' LONG		
		MATERIAL		ENG APPR.					
		FINISH		MFG APPR.					
NEXT ASSY	USED ON	DO NOT SCALE DRAWING		Q.A.			SIZE	DWG. NO.	REV
APPLICATION				COMMENTS:			B	BL-TIMERSTABLE-18	01
						SCALE: 1:32 WEIGHT:		SHEET 2 OF 5	

NOTES:

SEE SHEET 1 FOR BALLOON ITEM QUANTITIES

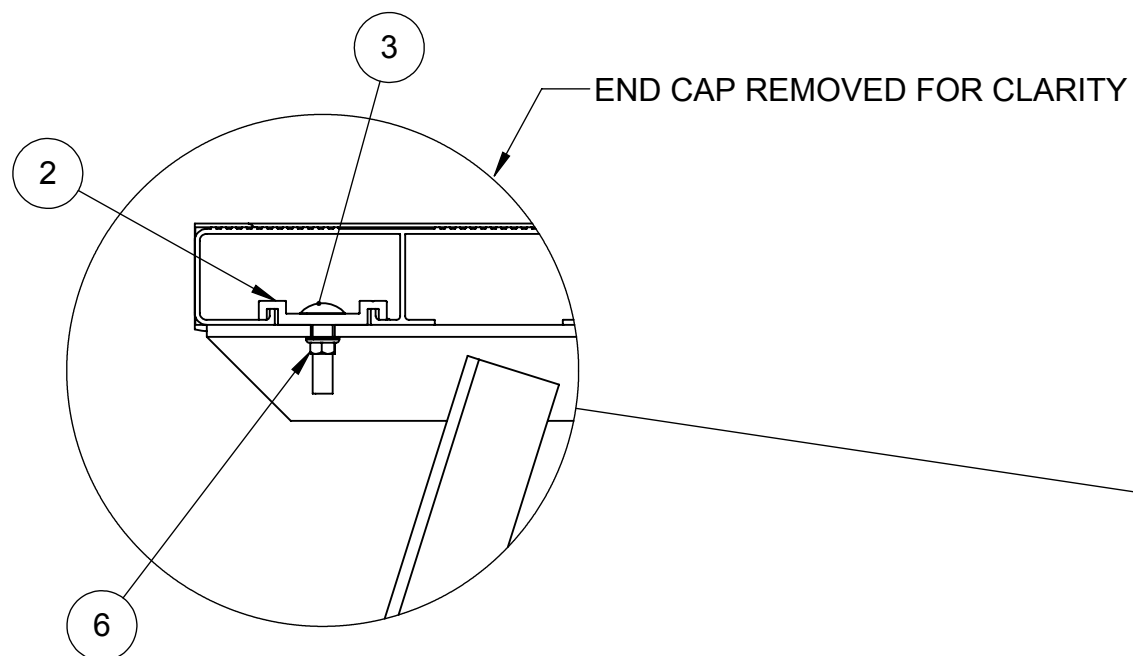

DETAIL A
SCALE 1 : 3

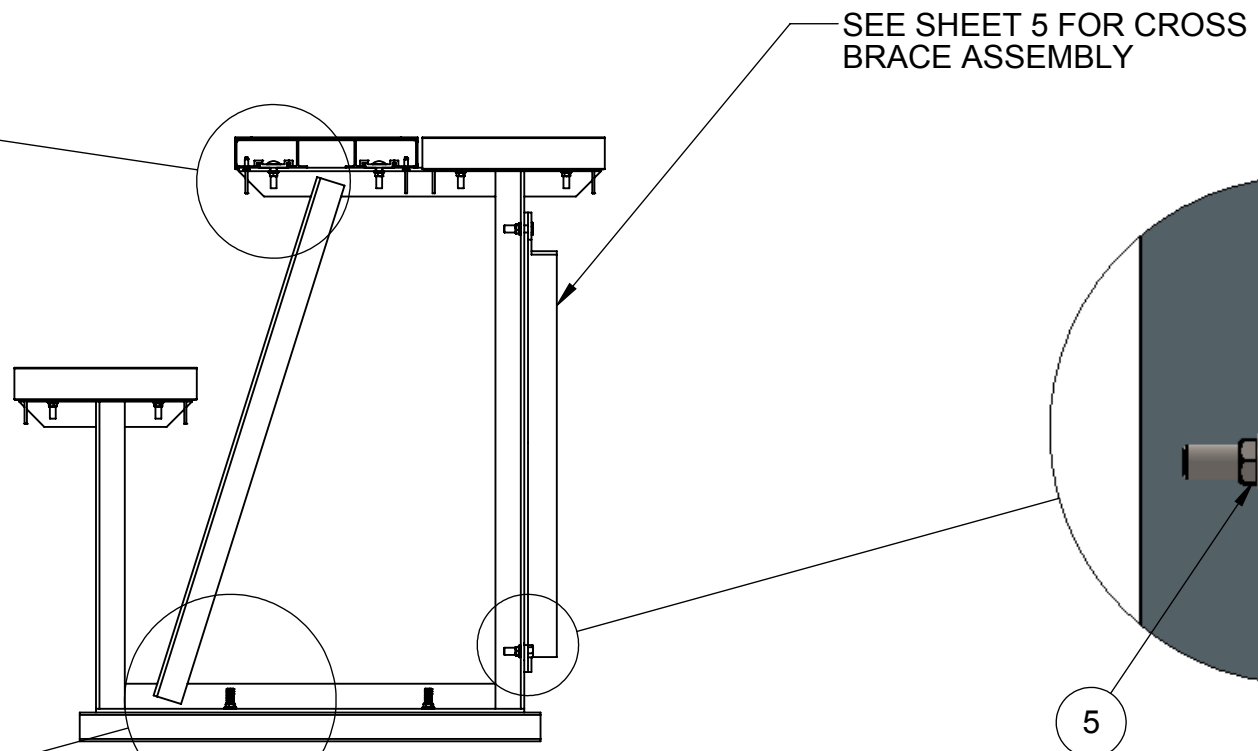

RIGHT SIDE ELEVATION
ITEM 1 STRINGER ASSEMBLY

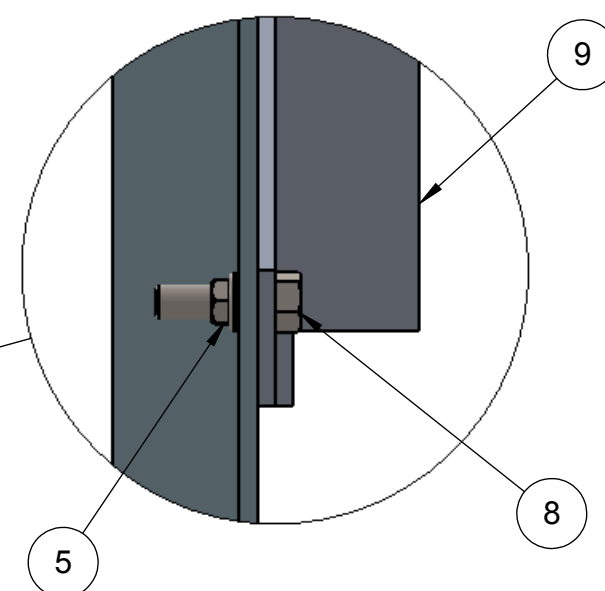

DETAIL C
SCALE 1 : 2

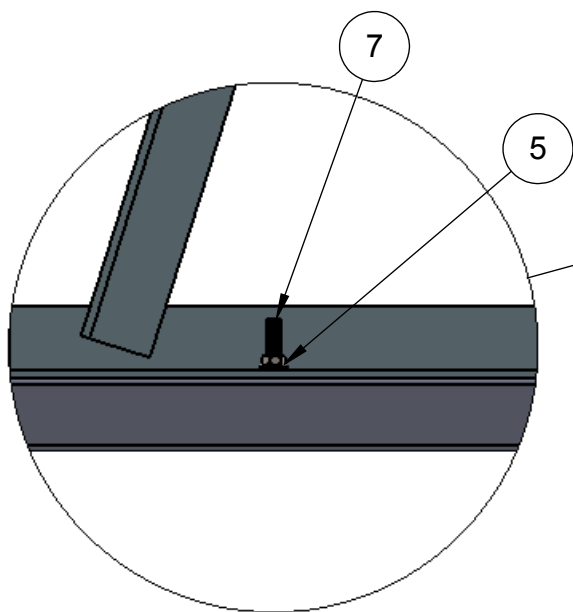

DETAIL B
SCALE 1 : 4

PROPRIETARY AND CONFIDENTIAL
THE INFORMATION CONTAINED IN THIS DRAWING IS THE SOLE PROPERTY OF <INSERT COMPANY NAME HERE>. ANY REPRODUCTION IN PART OR AS A WHOLE WITHOUT THE WRITTEN PERMISSION OF <INSERT COMPANY NAME HERE> IS PROHIBITED.

		UNLESS OTHERWISE SPECIFIED:		NAME	DATE	S.S.C.I.	
		DIMENSIONS ARE IN INCHES TOLERANCES: FRACTIONAL ± ANGULAR: MACH ± BEND ± TWO PLACE DECIMAL ± THREE PLACE DECIMAL ±		DRAWN	John Cox		
		INTERPRET GEOMETRIC TOLERANCING PER:		CHECKED			TITLE: TIMER'S TABLE 18' LONG
		MATERIAL		ENG APPR.			
NEXT ASSY	USED ON	FINISH		MFG APPR.			SIZE B
APPLICATION		DO NOT SCALE DRAWING		Q.A.			DWG. NO. BL-TIMERSTABLE-18
				COMMENTS:			REV 01
							SCALE: NTS
							WEIGHT:
							SHEET 3 OF 5

8 7 6 5 4 3 2 1

NOTES:

USING A 3/16" DRILL BIT, DRILL FOUR HOLES THROUGH (ITEM 10) AND (ITEM 11) AS SHOWN.
INSERT (ITEM 12) FOUR PLACES

NOTES:

SEE SHEET 1 FOR BALLOON ITEM QUANTITIES

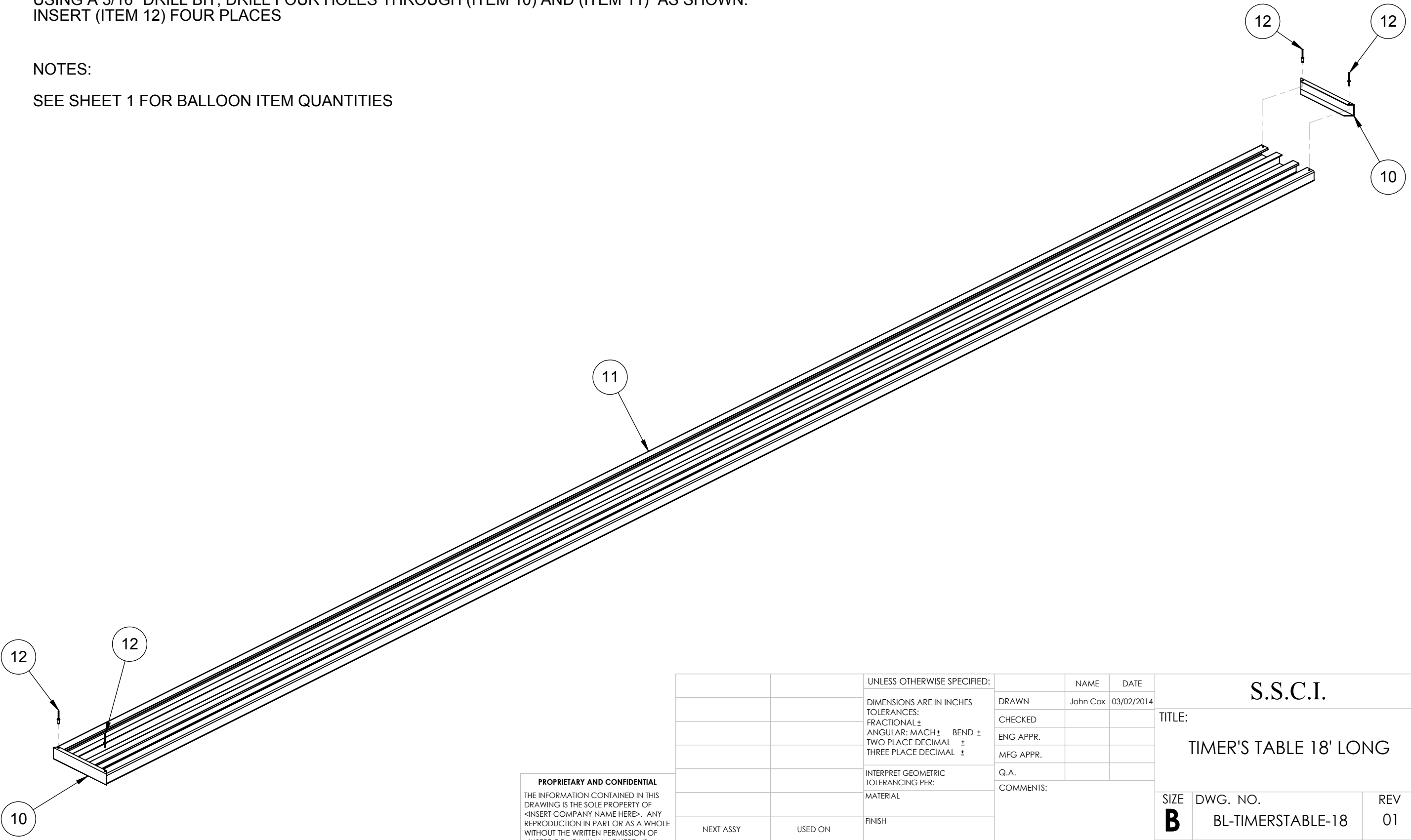

PROPRIETARY AND CONFIDENTIAL
THE INFORMATION CONTAINED IN THIS DRAWING IS THE SOLE PROPERTY OF <INSERT COMPANY NAME HERE>. ANY REPRODUCTION IN PART OR AS A WHOLE WITHOUT THE WRITTEN PERMISSION OF <INSERT COMPANY NAME HERE> IS PROHIBITED.

		UNLESS OTHERWISE SPECIFIED:		NAME	DATE	S.S.C.I.	
		DIMENSIONS ARE IN INCHES TOLERANCES: FRACTIONAL ± ANGULAR: MACH ± BEND ± TWO PLACE DECIMAL ± THREE PLACE DECIMAL ±		DRAWN	John Cox		
		INTERPRET GEOMETRIC TOLERANCING PER:		CHECKED			TITLE: TIMER'S TABLE 18' LONG
		MATERIAL		ENG APPR.			
		FINISH		MFG APPR.			
NEXT ASSY	USED ON			Q.A.			SIZE B
APPLICATION		DO NOT SCALE DRAWING		COMMENTS:			DWG. NO. BL-TIMERSTABLE-18
							REV 01
							SCALE: NTS
							WEIGHT:
							SHEET 4 OF 5

8 7 6 5 4 3 2 1

NOTES:
SEE SHEET 1 FOR BALLOON ITEM QUANTITIES

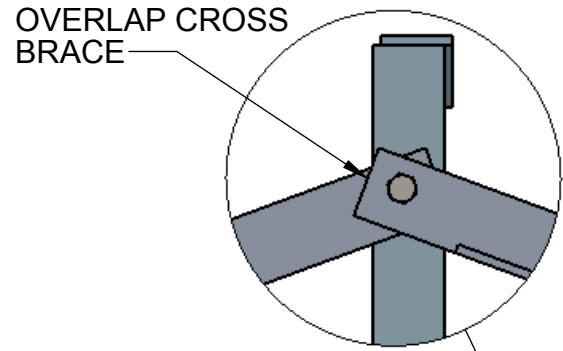

DETAIL D
SCALE 1 : 4

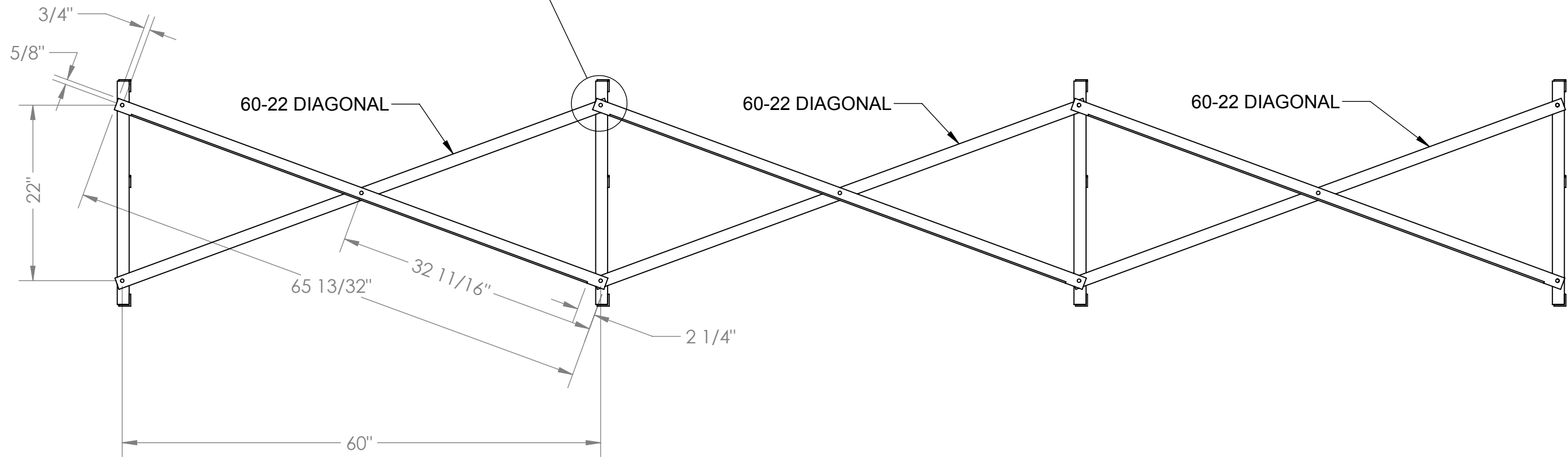
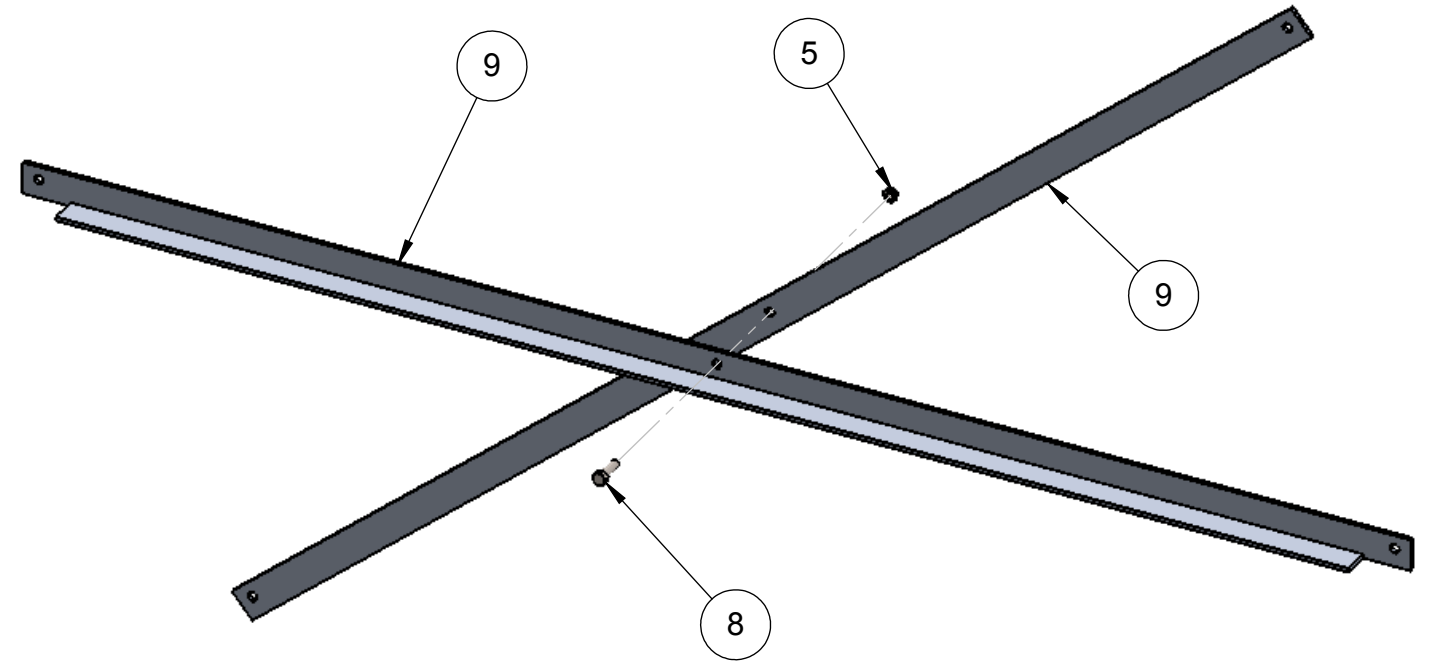

PROPRIETARY AND CONFIDENTIAL
THE INFORMATION CONTAINED IN THIS DRAWING IS THE SOLE PROPERTY OF <INSERT COMPANY NAME HERE>. ANY REPRODUCTION IN PART OR AS A WHOLE WITHOUT THE WRITTEN PERMISSION OF <INSERT COMPANY NAME HERE> IS PROHIBITED.

		UNLESS OTHERWISE SPECIFIED:		NAME	DATE	S.S.C.I.	
		DIMENSIONS ARE IN INCHES TOLERANCES: FRACTIONAL ± ANGULAR: MACH ± BEND ± TWO PLACE DECIMAL ± THREE PLACE DECIMAL ±		DRAWN	John Cox		
		INTERPRET GEOMETRIC TOLERANCING PER:		CHECKED			TITLE: TIMER'S TABLE 18' LONG
		MATERIAL		ENG APPR.			
		FINISH		MFG APPR.			
NEXT ASSY	USED ON	DO NOT SCALE DRAWING		Q.A.			SIZE
APPLICATION				COMMENTS:			DWG. NO.
							B
							BL-TIMERSTABLE-18
							REV
							01
							SCALE: 1:8
							WEIGHT:
							SHEET 5 OF 5